



# KING

Unicità di stile





# TRASPARENZA E VISIBILITÀ

---



# PUREZZA ESPOSITIVA

La massima panoramicità per esaltare le caratteristiche del prodotto esposto



# ELEGANZA DEI DETTAGLI

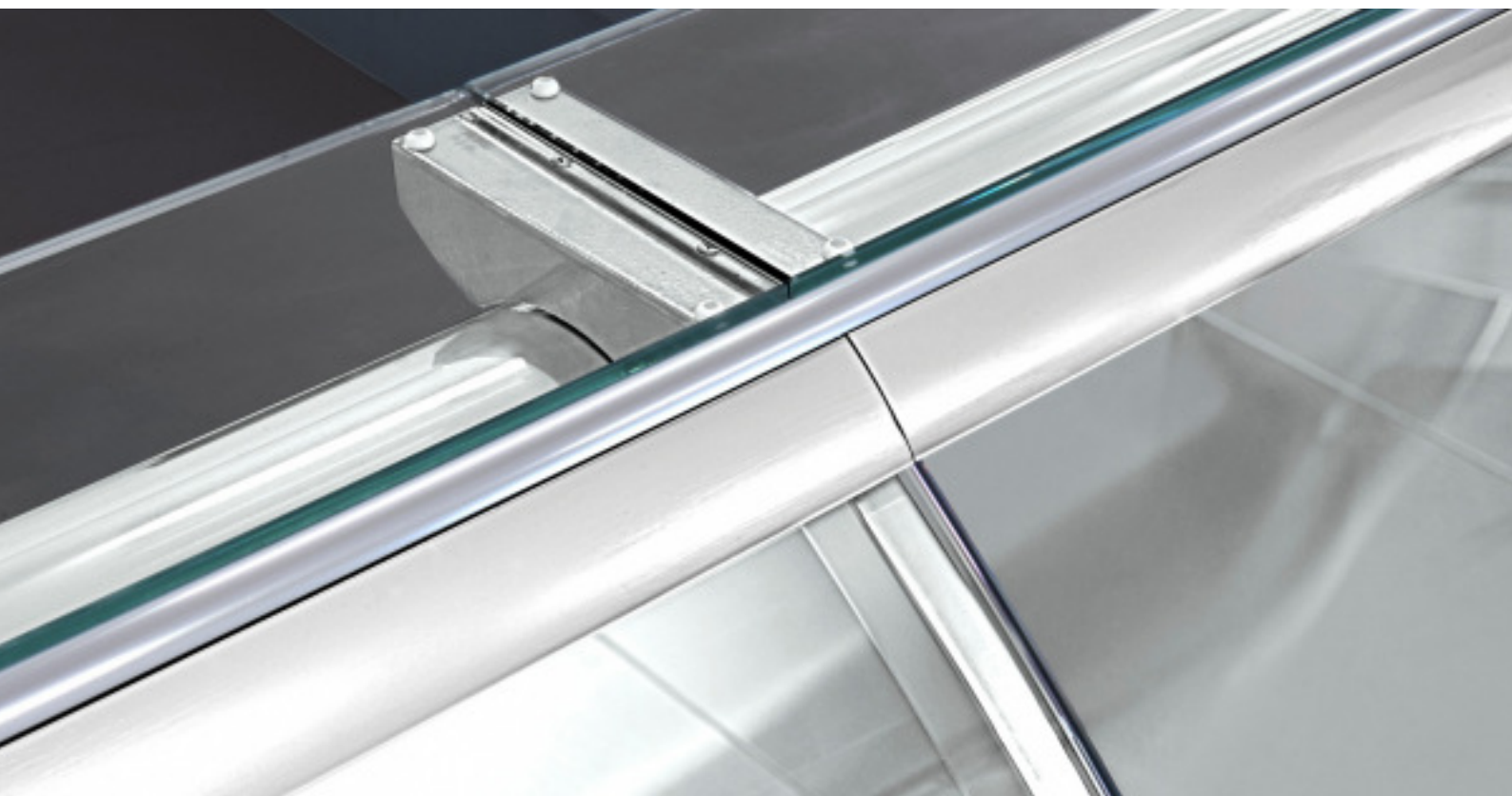



# DOPPIO STATICO

L'ideale per la conservazione e l'esposizione delle carni



## PROGETTO ESCLUSIVO PASTORFRIGOR.

Piattelli espositivi refrigerati e ribaltabili mediante pistoni.

# CARATTERISTICHE TECNICHE.

KING



Colori RAL Standard ( per i decori frontali bassi)

1015	1021	2011
3002	3020	5005
5012	6018	7035
7037	9006	9010

## Dotazioni di serie:

- Banco remoto con valvola termostatica
- Vasca in acciaio inox
- Refrigerazione ventilata
- Ventilazione frontale antiappannante
- Zona espositiva in acciaio inox
- Illuminazione superiore singola T8
- Vetri curvi con montante anteriore, sollevabili con pistoni e rendiresto fisso
- Quadro comando morsettiera
- Ventilatori elettronici a basso consumo
- Batticarrello in acciaio inox

## Dotazioni opzionali:

- Divisori fissi e mobili
- Illuminazione frontale T5
- Illuminazione Led / Illuminazione doppia T5
- Mensole intermedie
- Chiusure posteriori plexi
- Piani espositivi a più livelli
- Portacarta - Portabilancia
- Tagliere
- Valvola elettronica
- Spalle panoramiche
- Quadri comando master e slave

KING

	1250	1875	2500	3125	3750	45° E	45° I	90° E	90° I	937
Carni	•	•	•	•	•	•	•	•	•	•
Salumi e Latticini	•	•	•	•	•	•	•	•	•	•
Pane	•	•	•	•	•					•
Tavola calda	•									•
Gelati	•		•		•					
Surgelati	•		•		•					
Pesce	•		•		•					
Pasticceria	•		•		•					



# SEZIONI

## KING

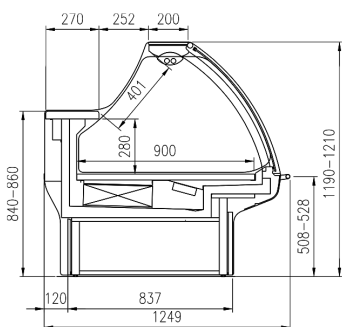

KING Meat/Gastronomy

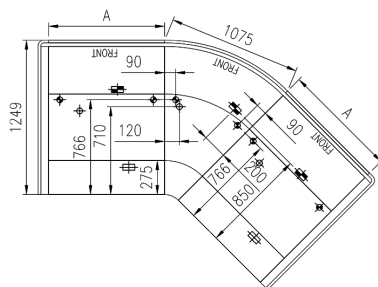

KING 45°E

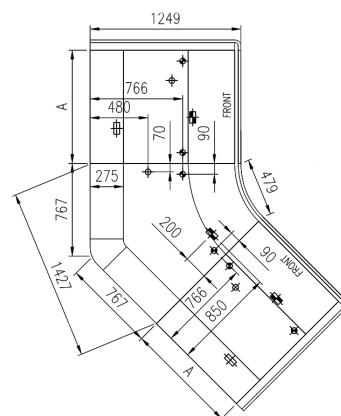

KING 45°I

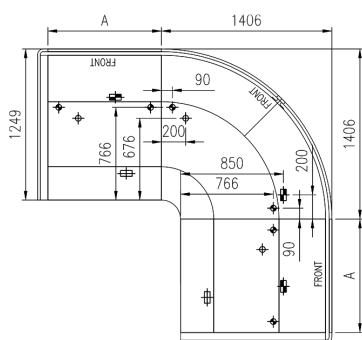

KING 90°E

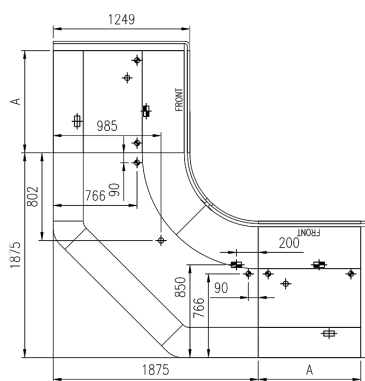

KING 90°I

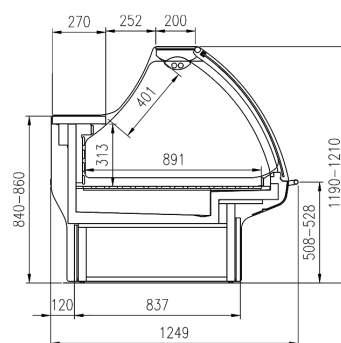

KING Bread

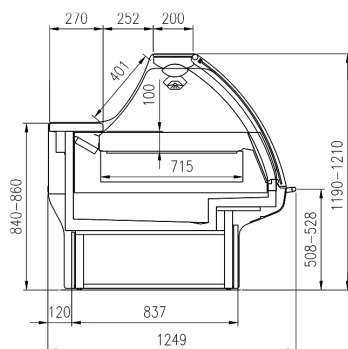

KING Hot Section

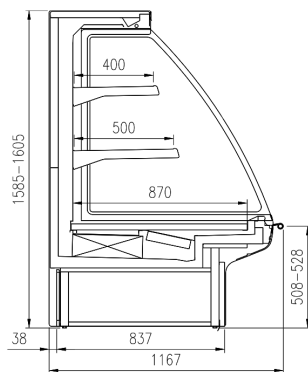

KING BMM

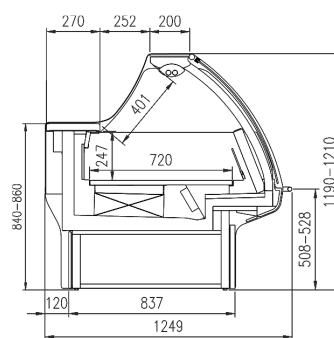

KING Low Temperature

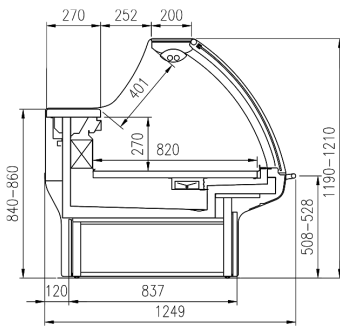

KING Double Static

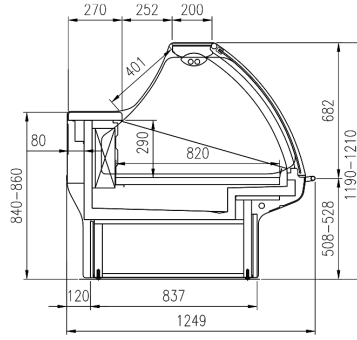

KING Fish

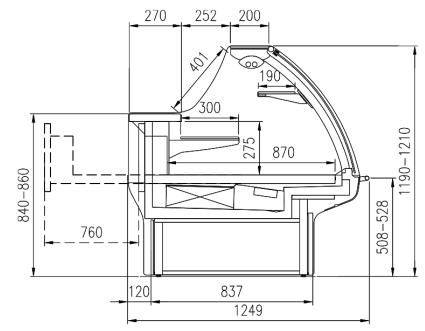

KING Pastry

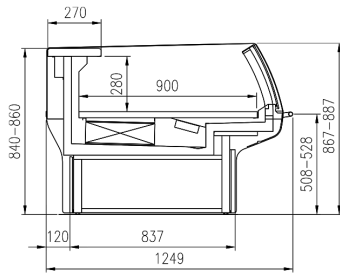

KING SS



**pastorfrigor**  
Italian Cold Style 

Pastorfrigor Spa  
15030 Terruggia (AL) - Italy - Reg. Gabannone, 4 Z.I.  
Tel. +39 0142.433.711 - Fax +39 0142.433.701  
info@pastorfrigor.it - www.pastorfrigor.it  
P.IVA 00578270068

Le immagini e le caratteristiche dei prodotti contenute in questo catalogo non tengono conto di eventuali modifiche o aggiornamenti e le configurazioni proposte non sono vincolanti. Ogni riproduzione è vietata.  
Las imágenes y las características de los productos contenidos en este catálogo no tienen en cuenta posibles modificaciones o actualizaciones y las configuraciones propuestas no son vinculantes.  
Queda prohibida la reproducción total o parcial. Las imágenes et les caractéristiques des produits mentionnées dans ce catalogue ne tiennent pas compte des modifications ou des mises à jour et les configurations proposées ne sont pas contraignantes. Toute reproduction est interdite.