



MILANO

Un classico di funzionalità





UN CAMPIONE DI VERSATILITA



MILANO

FLESSIBILITA DI UTILIZZO

Canalizzabile linearmente o back to back con o senza testata



CARATTERISTICHE TECNICHE

MILANO



Colori RAL Standard

1015	1021	2011
3002	3020	5005
5012	6018	7035
7037	9006	9010

Dotazioni di serie:

Refrigerazione ventilata con valvola termostatica
Ventilatori elettronici
Resistenza sbrinamento evaporatore
Valvola R404 a saldare
2 ripiani in griglia con portaprezzo
Batticarrello ABS

Dotazioni opzionali:

Batticarrello inox
Divisori
Predisposizione sbrinamento gas caldo
Illuminazione LED
Quadri comando master e slave
Porte Everclear
Opzione colori per finiture interne/esterne
Valvola elettronica
Coperture scorrevoli per vasca inferiore

MILANO

	1875	2200	2500	3750
MILANO Head-2E		•		
MILANO HG-1E	•		•	•
MILANO HG-2E	•			
MILANO NG-1E	•		•	•

SEZIONI

MILANO

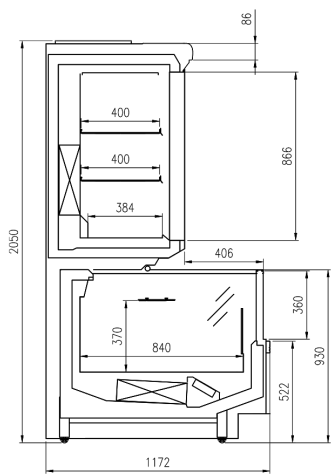

MILANO NG H205 Head

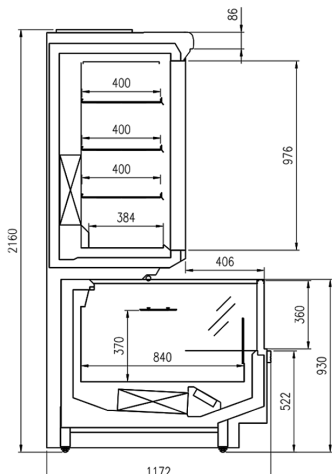

MILANO NG H216 Head

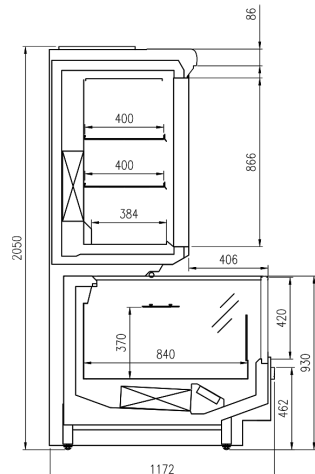

MILANO HG H205 Head

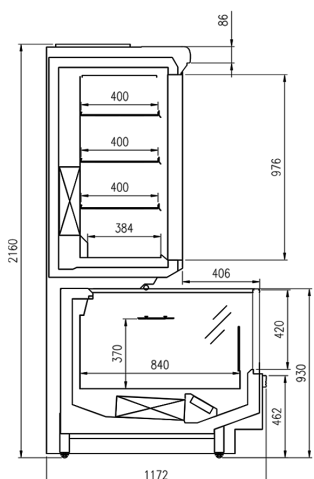

MILANO NG H216 Head

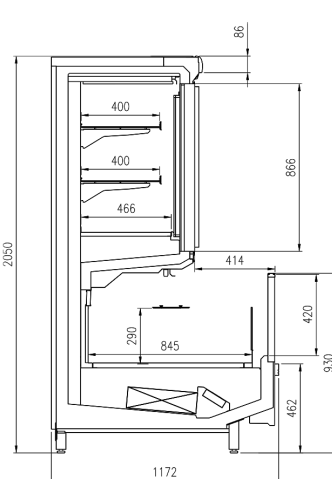

MILANO HG 1E H205

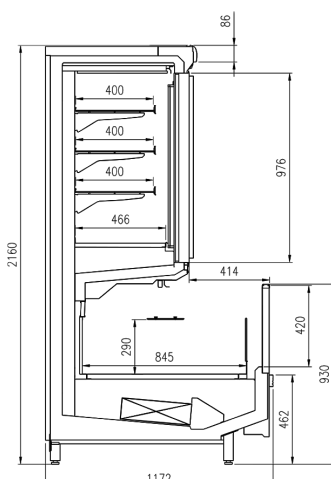

MILANO HG 1E H216

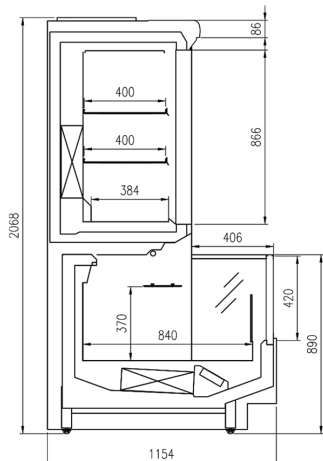

MILANO HG 2E H205

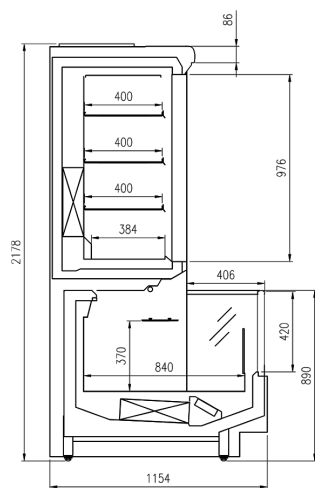

MILANO HG 2E H216

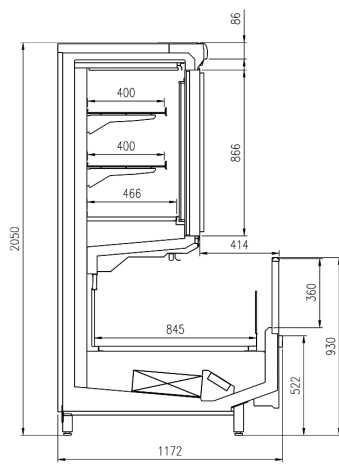

MILANO NG 1E H205

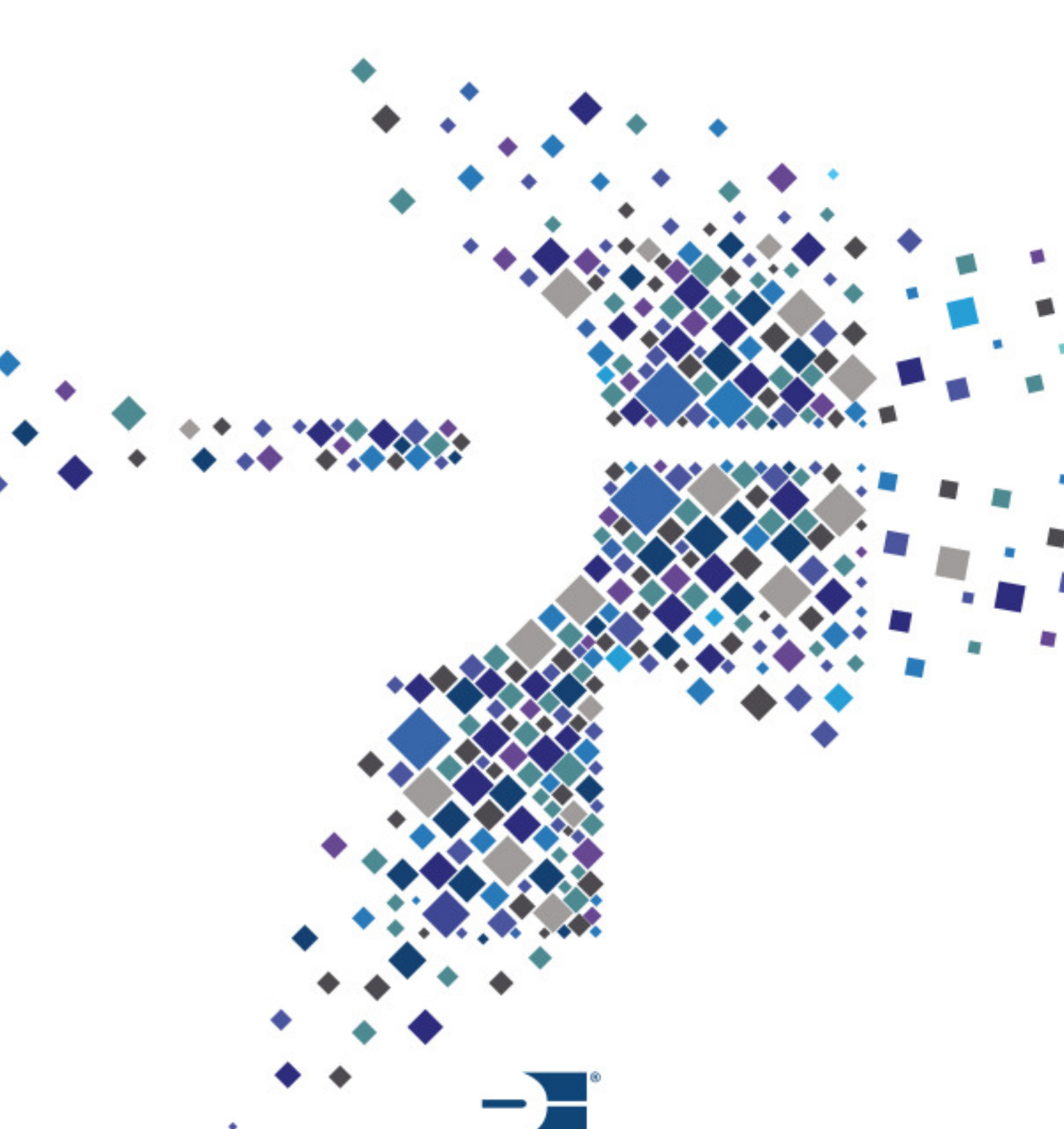

pastorfrigor
Italian Cold Style 

Pastorfrigor Spa
15030 Terruggia (AL) - Italy - Reg. Gabannone. 4 Z.I.
Tel. +39 0142.433.711 - Fax +39 0142.433.701
info@pastorfrigor.it - www.pastorfrigor.it
P.IVA 00578270068